

# CAT40 Mill Chucks



## Features

- 5  $\mu\text{m}$  - 0.0002" Runout @ 4 x Cutter Shank Dia.
- Designed for Tool Shanks w/ ISO h6 Class Tolerance
- Pre-Balanced for use @ 20,000 RPM
- Tapers are ground better than AT3 for optimal T.I.R.

## Optional (Order Separately):

- Wrench
- Nylon Screw Seal for short tool shanks
- DIN-B Flange Coolant
- Fine Trim Balance  
(Sample cutter required for balance compensation)

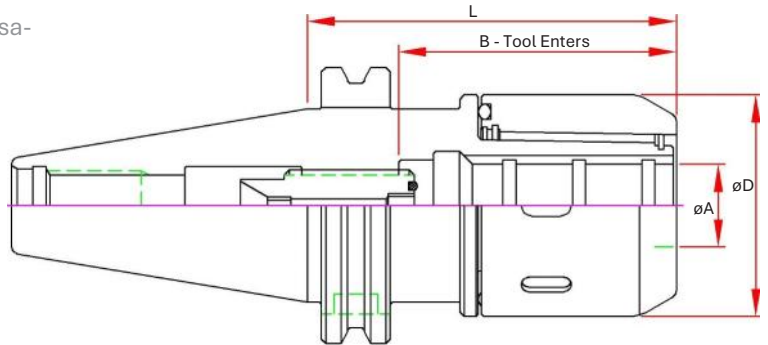

Part Number	A Bore	B Max. Tool Enters	D	L Projection	Preset Screw	Collet	Wrench
CAT40-MC075-0276				2.76			
CAT40-MC075-0335	0.7500	2.76	2.09	3.35	ASC-16-40	MC075	50-55 HOOK
CAT40-MC075-0472				4.72			
CAT40-MC075-0591				5.91			
CAT40-MC100-0335				3.35			
CAT40-MC100-0374	1.0000	2.91	2.44	3.74	ASC-16-40	MC100	58-65 HOOK
CAT40-MC100-0413				4.13			
CAT40-MC100-0591				5.91			
CAT40-MC125-0354 *				3.54			
CAT40-MC125-0413	1.2500	3.07	2.76	4.13	ASC-16-40	MC125	65-70 HOOK
CAT40-MC125-0472				4.72			
CAT40-MC125-0591				5.91			

\* No ANSI Safety Area - will not function in umbrella style tool changers

CAT 40

CAT50

BT30

BT40

HSK 40E

HSK 63A

HSK 100A

STR. SHANKS

COLLETS

ACC.

SHRINK MACH

INDEXERS

