

Mill Chuck Operation

1. Cutting tools must have an ISO shank tolerance of h6 (0 / -0.0005”).
2. It is strongly recommended that the cutting tools have a straight cylindrical shanks to optimize performance. Reducing sleeves (collets) should not be used if possible because holding power is reduced 2-6X using reducing sleeves. Mill Chucks are designed for direct drive without a reducing sleeve (collet). For best performance keep flats on the cutting tools to a minimum.
3. Clean the ID of the Chuck, ID and OD of the Collet and the OD of the tool shank
4. Firmly hold the mill chuck with a tool fixture. Insert the collet or cutter shank into the ID of the MC Chuck, for proper holding the round part of the cutting shank must engage the complete bore depth. When using reducing sleeves (collets) verify the round portion of the cutting tool shank enters the complete length of the collet bore.
5. Tighten the nut using the proper wrench. Tighten the nut all the way down until the O-ring located at the bottom of the nut touches the flange of the body.
Note: The nut hitting the shoulder will cause additional TIR. See Step 6.
6. Back off 1/8 - 1/4 turn for semi-finishing and finishing applications, TIR is restored the holder is back to where it was ground.
7. DO NOT tighten the mill chuck without a cutting tool shank inserted. This may cause damage to the mill chuck, or loss of performance.
8. DO NOT tighten past the O-ring touching the body. Over tightening does not increase pressure and damages the bearings in the nut.
9. When changing tools and storing mill chucks it is important to loosen the mill chuck nut completely and disengage the nut until it spins freely. This allows the bearing to return to the home position.
10. If there is noticeable corrosion or wear on the mill chuck ID, taper of the shank, or excessive unsmooth feeling when tightening or loosening the mill chuck nut, please stop using the mill chuck and contact your local service center.

Due to the tolerance variance of the cutter shanks and pressure required a tightening torque value is not supplied. The procedure above if followed will allow the holder to operate for many years without issue.

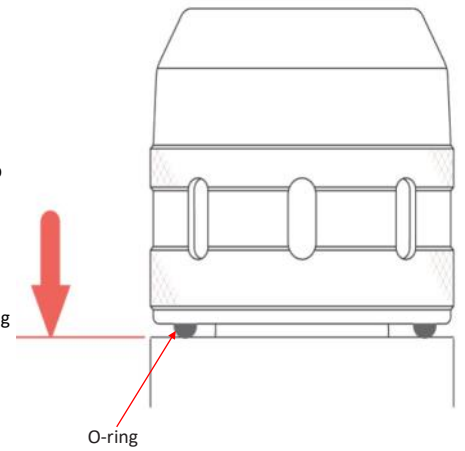

BC MILL
CHUCKS

MX VX MINI
CHUCKS

SX COLLET
CHUCKS

SHRINK FIT

MILL CHUCK

ER COLLET
CHUCKS

EM END MILL
ADAPTERS

SM SHELL MILL
ADAPTERS

QC Tap

TG COLLET
CHUCK

Drill Chucks
Test Bars

ACC

Rotary
Indexers