

Lathe Coolant Thru Straight Shank

Features

- 3 μm - 0.0001" Runout Taper to Taper
- Coolant Thru Body (see chart)
- Includes 1/4" Pipe Threads

Optional (Order Separately):

- Wrench
- Torque Wrench
- Collets



Part Number	Collet Type	D1	D2	L1	L2	T- Thread	Set Screw	Max Tool Dia.	Wrench	Nut Type
S075-ER16M-0342C	ER16	0.7500	0.87	4.34	3.42		ASC-ER16	0.38	ERW-16M	Mini
S100-ER20M-0331C	ER20	1.0000	1.10	4.38	3.31	1/4" NPT	ASC-ER20	0.50	ERW-20M	Mini
S125-ER32-0236C	ER32	1.2500	1.97	4.52	2.36		ASC-ER32	0.75	ERW-32E	E-Spanner

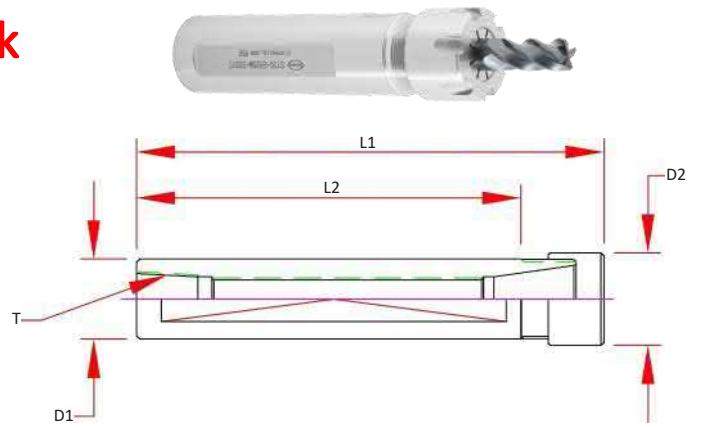

Lathe ER Straight Shank

Features

- 3 μm - 0.0001" Runout Taper to Taper
- Coolant Thru Body (see chart)
- Includes O-Ring Shank Seal

Optional (Order Separately):

- Wrench
- Torque Wrench
- Collets



Part Number	Collet Type	D1	D2	L1	L2	L3	ID Thread	Wrench	Nut Type	O-Ring Shank Seal
S125-ER25-0236NC	ER25	1.2500	1.65	3.82	2.36	1.46	11/16-16	ERW-25E	E-Spanner	AS-024
S125-ER32-0236NC	ER32	1.2500	1.97	4.06	2.36	1.69	15/16-16	ERW-32E	E-Spanner	AS-024
S125-ER40-0236NC	ER40	1.2500	2.48	4.72	2.36	2.36	15/16-16	ERW-40E	E-Spanner	AS-024
S150-ER32-0315NC	ER32	1.5000	1.97	4.65	3.15	1.50	15/16-16	ERW-32E	E-Spanner	AS-028
S150-ER40-0295NC	ER40	1.5000	2.48	5.31	2.95	2.36	1 1/8-16	ERW-40E	E-Spanner	AS-028

