

Direct Drive CNC Rotary Table
with Controller, Debut!!



DRC170-AC5-60A

Direct Drive CNC Rotary Table with Controller DRC170-AC5-60A



- High Speed
- Quick Clamp
- Quick Indexing
- Powerful Clamp
- High-resolution Absolute Encoder
- No Backlash
- Built-in Auto Purging System

- Low Cost
- Compact Body
- Various Program Functions
- Easy Connection
- Various Interlock
- Environment Resistance
- Trouble Diagnosis
- Supporting Manual Pulse Handle

DRC170		
Table dia.	mm	140
Center height	mm	135
Center faucet dia.	mm	50H7
Table center through hole dia.	mm	46
Clamp system	MPa	Air 0.3~1.0
Clamp torque (N·m)	no air	100
	0.3MPa	350
	0.5MPa	600
	1.0MPa	900
Allowable work load (N)	Vert.	3,400
	Hori.	2,300
	Circ.	2,400
Table rotation torque	N·m	45
Table rotation speed	min ⁻¹	200 300
Allowable inertia moment	kg·m ²	0.5 0.25
Total reduction ratio		1/1
Index accuracy(cumulatively)	sec.	15
Repeatable accuracy	sec.	4
Weight(without cable)	kg	76

AC5-60A	
Rated curr. (Max. curr.)	7A(21A)
AC power supply	3φ200~230V,+10~-15%,50/60Hz
W×H×D, weight	260mm×259mm×248mm, 10.0kg
Setting Unit,	0.001°, ±999.999°, ±999 revolutions
Max. Command angle	(Up to ±5965 revolutions)
Max.Rapid rotation speed	72000(108000) [°] /min,():300min ⁻¹
Operation mode	Auto/Manual/Machine zero return/Work zero return/Jog/Program edit/Parameter setting
Program input	Keyboard/Serail interface(RS232C)
Program function	Equal division/Unequal division/Sector division/Multiple rotation/Continuous start/Interlocking start/Machine zero return/Sub-program
External Program selection	Binary : 16 programs M signal mode : 100 programs
Zero return	Machine zero point/Work zero point
Jog feed	1 pulse feed/Jog feed/ Jog feed speed select
Interlocking input signal	Start/Zero return/Interlock/ Program selection 0~3/Program set/ Emergency stop (normal close)
Interlocking output signal	FIN1,2/Ready/Alarm
Manual pulse handle	Optional



PIONEER N.A.

641 FARGO AVE.
ELK GROVE VILLAGE, IL 60007

www.PioneerNA.com | sales@PioneerNA.com



Overall dimensional drawing DRC 170

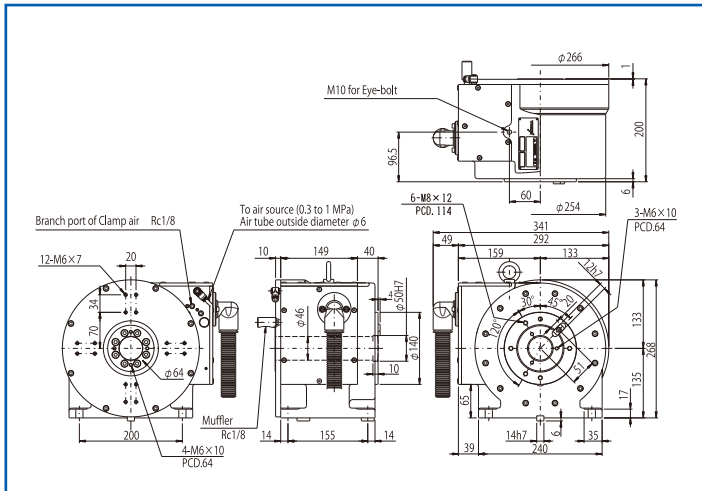

Overall dimensional drawing AC5-60A

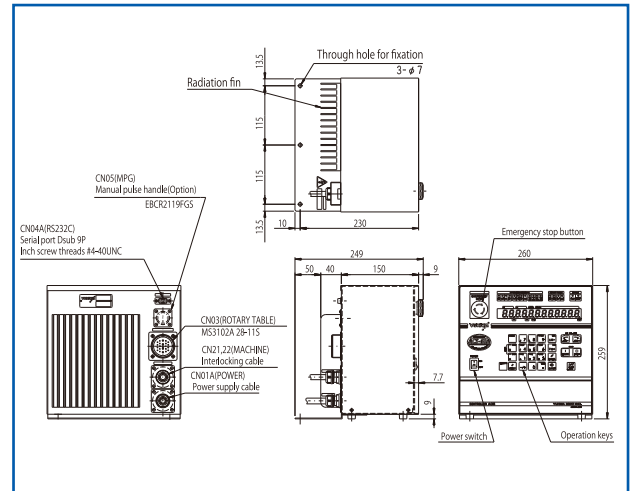

Components

